



Qumit Al-Amood Engineering



Architecting the Green Data Center

www.alamoodengineering.com

Bicsi[®]
INDIVIDUAL
MEMBER



Qumit Al-Amood Engineering

Power Consumption Mitigation What does "Green" Mean to You?

Political	Blue State, Red State Green Party Regulatory Compliance?
Health	Trader Joe's Whole Foods Walmart
Social	Hybrid's Bottled Water
Technology	Blades Scalable UPS Fuel Cells
Economics	Cost Centers Selective Accounting
YOU?	Control Influence



ZAIN +964 (0) 790-315-5118

www.alamoodengineering.com

ZAIN +964 (0) 781-201-8226

info@alamoodengineering.com

ASIACELL +964 (0) 770-434-0798



Qumit Al-Amood Engineering

Damage Status

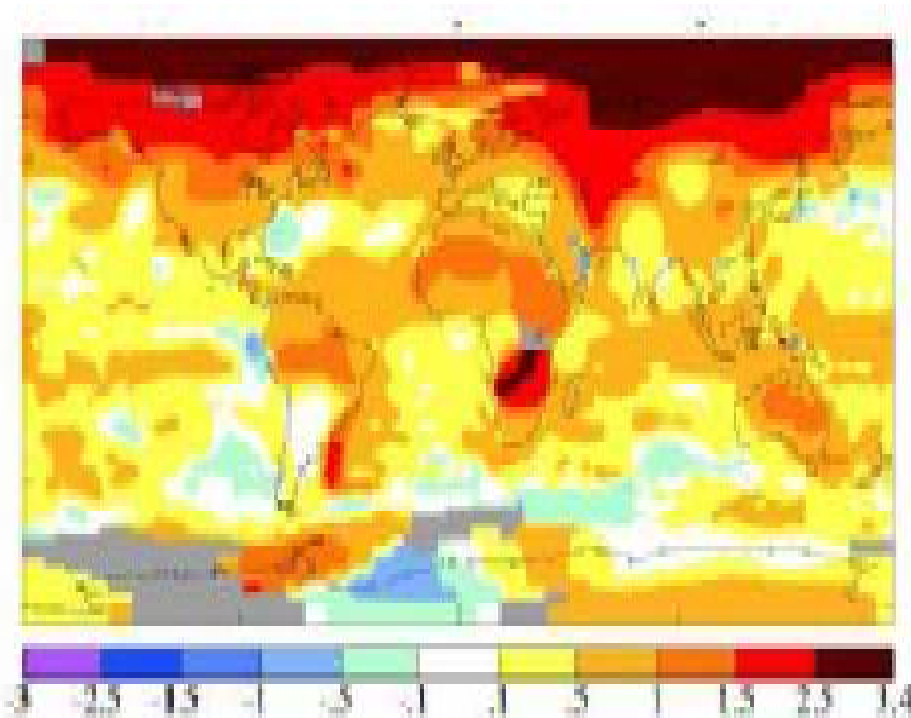

Source: J. Hansen, B. Ruedy, M. Sato, and K. Lo. GISS Surface Temperature Analysis—Global Temperature Trends: 2006 Summation. NASA, Goddard Institute for Space Studies and Columbia University Earth Institute, New York, NY 10025, USA. See <http://data.giss.nasa.gov/gistemp/2006/>, accessed June 4, 2006. Scale shows the deviation in average annual temperatures from long-term averages. The northern-most parts of the northern hemisphere recorded the highest deviations in 2006.

ZAIN +964 (0) 790-315-5118

www.alamoodengineering.com

ZAIN +964 (0) 781-201-8226

info@alamoodengineering.com

ASIACELL +964 (0) 770-434-0798



Qumit AI-Amood Engineering

Where does the Money Go?

Losses in power generate heat

- Operating Expense
- Electricity 27%
- Eng/Install 19%
- Power Infra 17%
- Space 17%
- Cooling Infra 6%

Power and cooling exceeds server Spending – IDC 2006

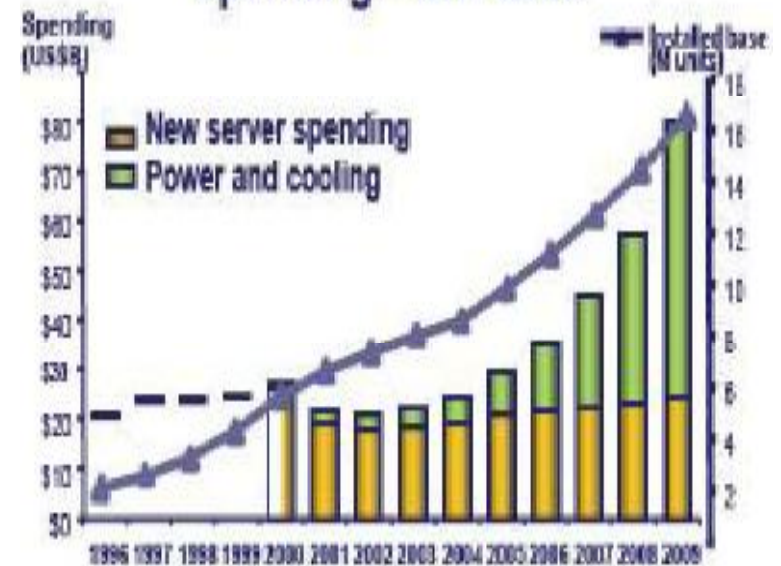



Qumit Al-Amood Engineering

Where does the Power Go? Losses in power generate heat

Each watt consumed by IT infrastructure carries a “burden factor” of 1.8to 2.5 for power consumption associated with cooling, conversion/distribution and lighting*

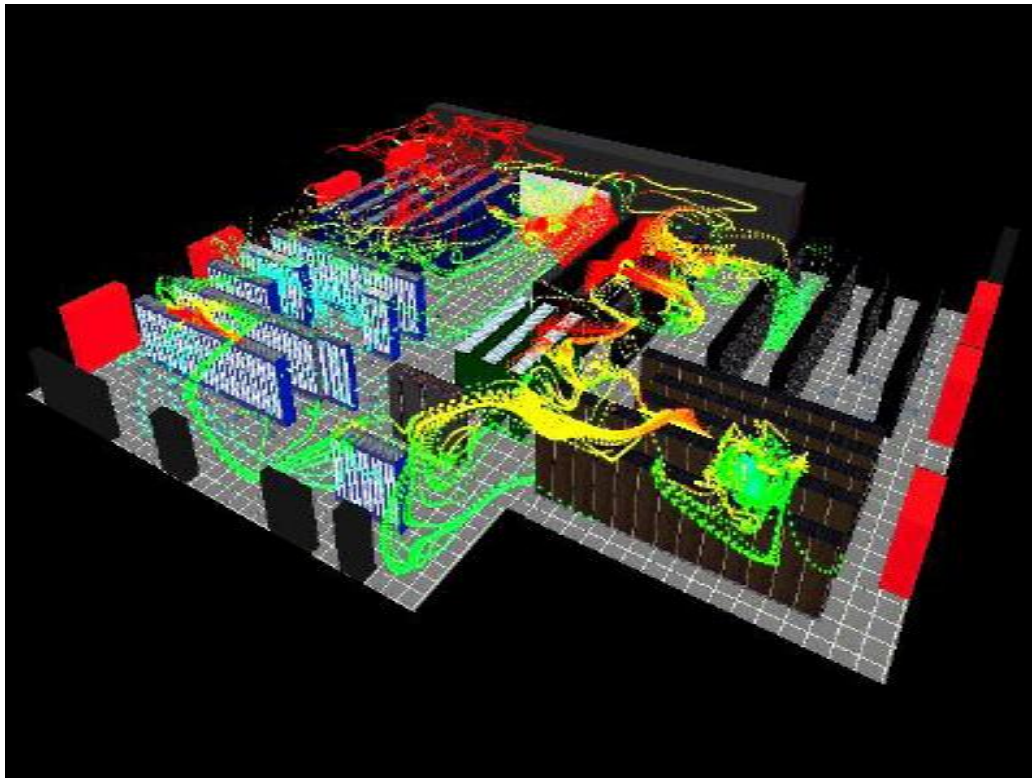

Power Supplied in the DC

CRAC 50%
Server/Storage 26%
Conversion 11%
Network 10%
Lighting 3%

ZAIN +964 (0) 790-315-5118

www.alamoodengineering.com

ZAIN +964 (0) 781-201-8226

info@alamoodengineering.com

ASIACELL +964 (0) 770-434-0798



Qumit Al-Amood Engineering

Putting Data Center Cooling Capacity Requirements in Perspective

- Typical Cooling Scenario / Heat Removal Capacity
- NEBS Maximum Data Center Cooling / 250 W/ft²
- Basic Data Center Cooling / 50 W/ft²
- Future High-Density Data Center Cooling / 700-800 W/ft² ?
- Commercial AC / 6-8 W/ft²
- Residential AC / 4-6 W/ft²

•Note: 1 person at rest generates approx 1.1 Watts in heat

ZAIN +964 (0) 790-315-5118

www.alamoodengineering.com

ZAIN +964 (0) 781-201-8226

info@alamoodengineering.com

ASIACELL +964 (0) 770-434-0798



Qumit Al-Amood Engineering

Calculating Efficiency and Operating Costs

- 1MW for 1 Year = \$ 486,618
- KW = KVA x Power Factor
- Operating cost of a 1000 KW UPS system, having a 90% efficiency, at \$0.10 per KWH, for one year at 50% load level
- Operating cost = 1000 KW x (1/.90 Efficiency at load level) x 8760 x \$ 0.10 x load level

Annual Operating Expense = \$800k

Legacy DC designed to accommodate 2-3kW per Rack 20,000 ft² 800kW

Annual Operating Expense = \$4.6M*

Introducing 1/3 high-density infrastructure into a legacy facility is cost prohibitive +33% 100-200 Racks

*Peripheral DC costs considered



Qumit Al-Amood Engineering

Intelligent Building Infrastructure Impact on Green Buildings

- Buildings account for:
 - 1/3 of all energy and 2/3 of all electricity used in the USA
 - 50% of SOX, 25% of NOX, and 35% of CO2 emissions
 - 25% of potable water use
 - \$ 220 billion in annual energy costs

US Department of Energy

- Efficient design
 - Optimized use of cabling and resources
- Sustainability
 - Ease of commissioning
 - Networked systems able to supply necessary information

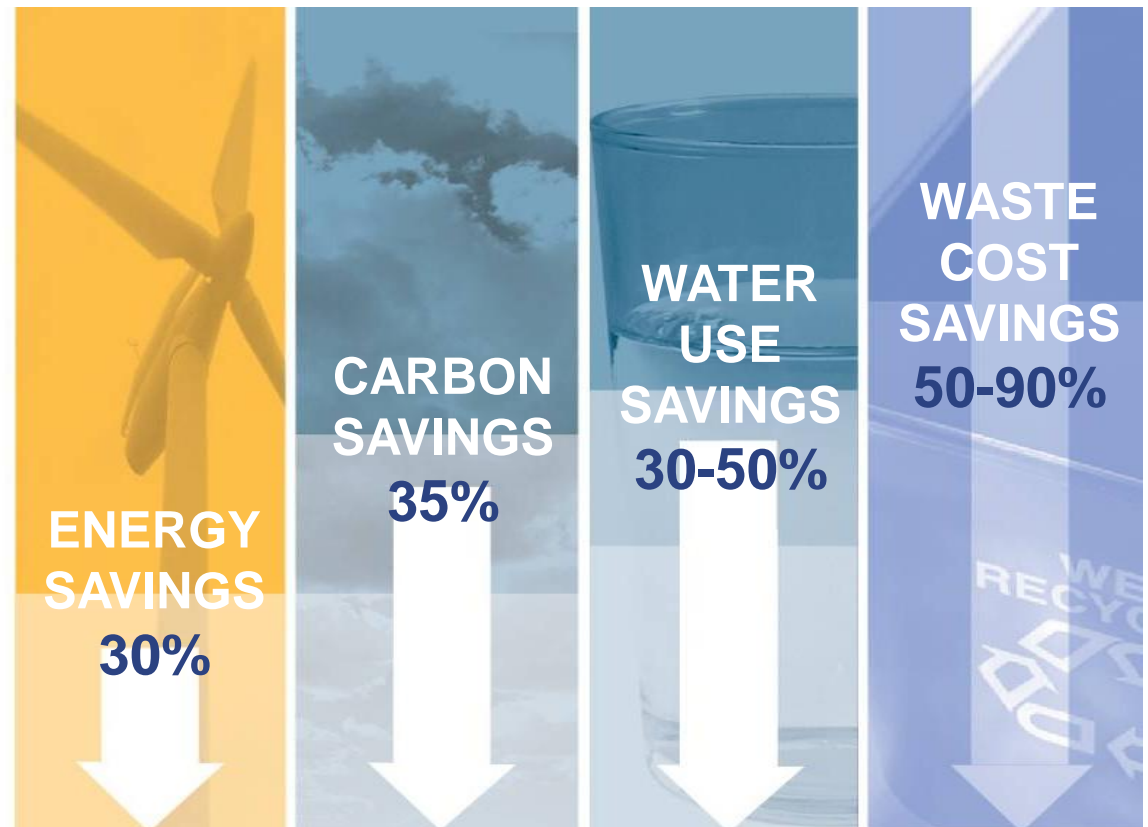

Source: Capital E and USGBC

ZAIN +964 (0) 790-315-5118

www.alamoodengineering.com

ZAIN +964 (0) 781-201-8226

info@alamoodengineering.com

ASIACELL +964 (0) 770-434-0798



Qumit Al-Amood Engineering

Data Center Evolution

Consolidation

- § Reduce Operating Expense
- § Can Strain Power Grids, HVAC Systems, and Control Planes
- § Also an Opportunity to "Audit" Power and Cooling Design

Power & Cooling

- § Reduce Component Count
- § Increases Density
- § Assessment Needed to Determine OPEX for site
- § Assessment may be Needed to Audit Existing CPI

Best Practices

- § Choose Efficient Components (Systems)
- § Balance Density/Space
- § Assess new Technology
- § Targeted, Incremental Changes for Efficiency
- § Virtualize to Increase Utilization
- § Share Practices



Evolving to Green

ZAIN +964 (0) 790-315-5118

www.alamoodengineering.com

ZAIN +964 (0) 781-201-8226

info@alamoodengineering.com

ASIACELL +964 (0) 770-434-0798



Qumit Al-Amood Engineering

Market Overview

- Today \$11 billion market
- 2009 growing to \$15 billion
- 50% of IT Manager's budgets will likely go to this area

Industry Forecasts

- Data center space will grow 40%/year (Source - IDC)
- Server units up 12.7%/year (IDC)
- AFCOM survey :-
 - Budgets increased 6-15% for 60% of respondents
 - Trend: The IT spending to business initiative to get 6 month payback

ZAIN +964 (0) 790-315-5118

ZAIN +964 (0) 781-201-8226

ASIACELL +964 (0) 770-434-0798

www.alamoodengineering.com

info@alamoodengineering.com



Qumit Al-Amood Engineering

Business Drivers

- § Mission Critical Applications
- § SLA - Service Level Agreements
- § Network Availability for Mobile Applications
- § Regulations/Directives
- § High Maintenance Costs of Legacy Networks
- § Virtualization
- § 24x7 Uptime Requirements

ZAIN +964 (0) 790-315-5118

www.alamoodengineering.com

ZAIN +964 (0) 781-201-8226

info@alamoodengineering.com

ASIACELL +964 (0) 770-434-0798



Qumit Al-Amood Engineering

Top of Mind Issues

- Reliability / Robustness
- Management/Operational Expense
- Security
- Future Proofing
- Cost of Deployment
- Scalability
- Remote Management
- Standards Compliance and Interoperability
- Vendors with Proven Success Record
- Easy to Design and Specify

ZAIN +964 (0) 790-315-5118

www.alamoodengineering.com

ZAIN +964 (0) 781-201-8226

info@alamoodengineering.com

ASIACELL +964 (0) 770-434-0798



Qumit Al-Amood Engineering

Top of Mind Issues

Top 5 challenges faced by enterprise IT infrastructure managers

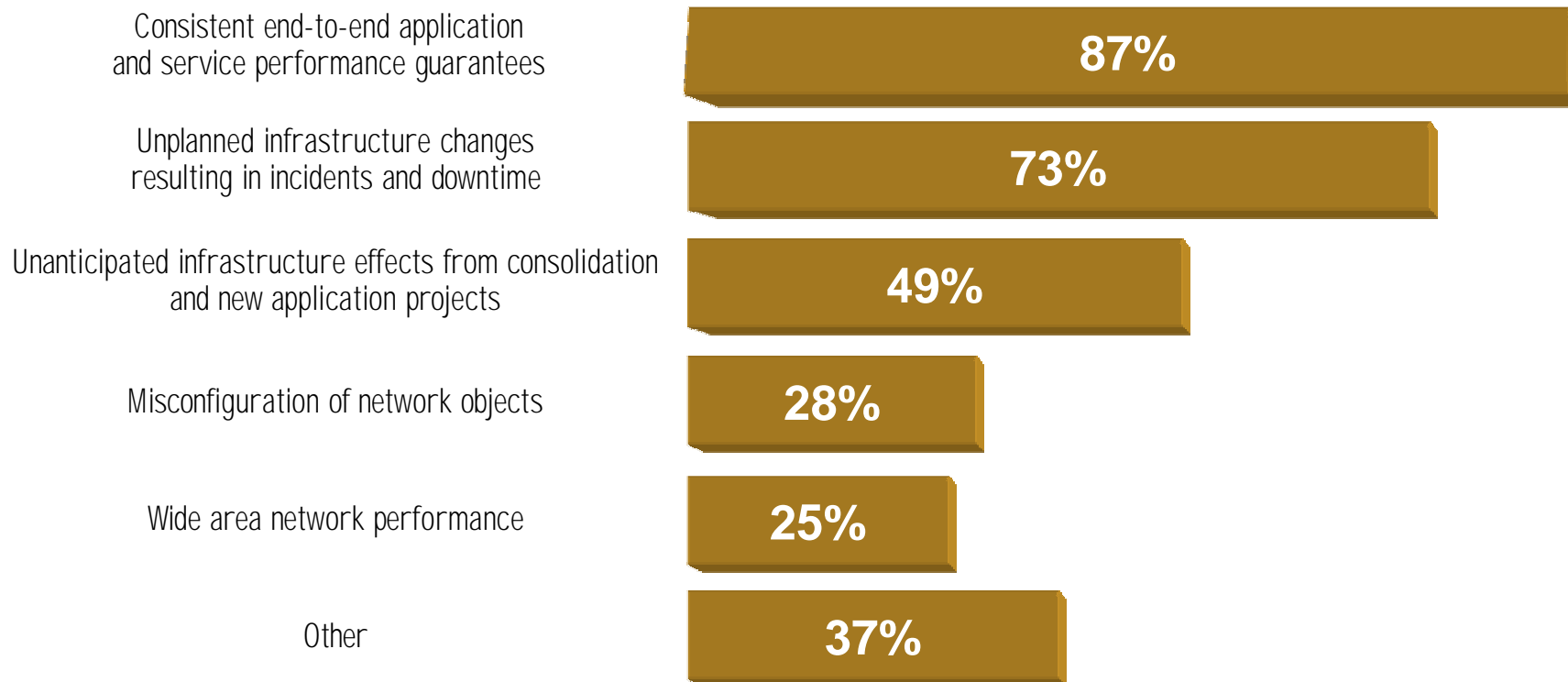

Question: "What are your top three issues in managing corporate IT infrastructure?"

Base: 67 enterprise IT infrastructure managers at \$1 billion-plus companies (multiple responses accepted)

Source: Forrester Research, Inc.

ZAIN +964 (0) 790-315-5118

ZAIN +964 (0) 781-201-8226

ASIACELL +964 (0) 770-434-0798

www.alamoodengineering.com

info@alamoodengineering.com



Qumit Al-Amood Engineering

Top of Mind Issues

Cost of Downtime/Availability for Various Industry Sectors

Industry Sector	Revenue / Hour	Revenue / Emp / Hour
Energy	\$2.81M	\$569
Telecommunication	\$2.06M	\$169
Manufacturing	\$1.61M	\$134
Financial Institutions	\$1.49M	\$1,079
Information Technology	\$1.34M	\$184
Insurance	\$1.20M	\$370
Retail	\$1.11M	\$244
Pharmaceuticals	\$1.08M	\$167
Banking	\$997K	\$131
Average	\$1,011K	\$206
Source: META Group		



Qumit Al-Amood Engineering

Data Center Standard

Telecommunications Infrastructure Standard for Data Centers, TIA-942



Qumit Al-Amood Engineering

Sample of Topics Covered

Telecommunications		
General / Standards to Follow		
Architectural		
Site Selection	Parking	Multi-Tenant
Building Construction	Building Components	Roofing
Doors & Windows	Entry Lobby	Admin Offices
Security Office	Operations Center	Restrooms/Break Areas
UPS / Battery Rooms	Exit Corridors	Shipping/Receiving
Generator/Fuel Storage	Security	Admin Offices
Security Access/Monitoring	CCTV	Structural
Electrical		
General	UPS	Grounding
EPO System	System Monitoring	Battery Room
Mechanical		
General	Water-Cooled Systems	Heat Rejection
Chilled Water System	Air Cooled Systems	Plumbing

ZAIN +964 (0) 790-315-5118

ZAIN +964 (0) 781-201-8226

ASIACELL +964 (0) 770-434-0798

www.alamoodengineering.com

info@alamoodengineering.com



Qumit Al-Amood Engineering

Building Blocks

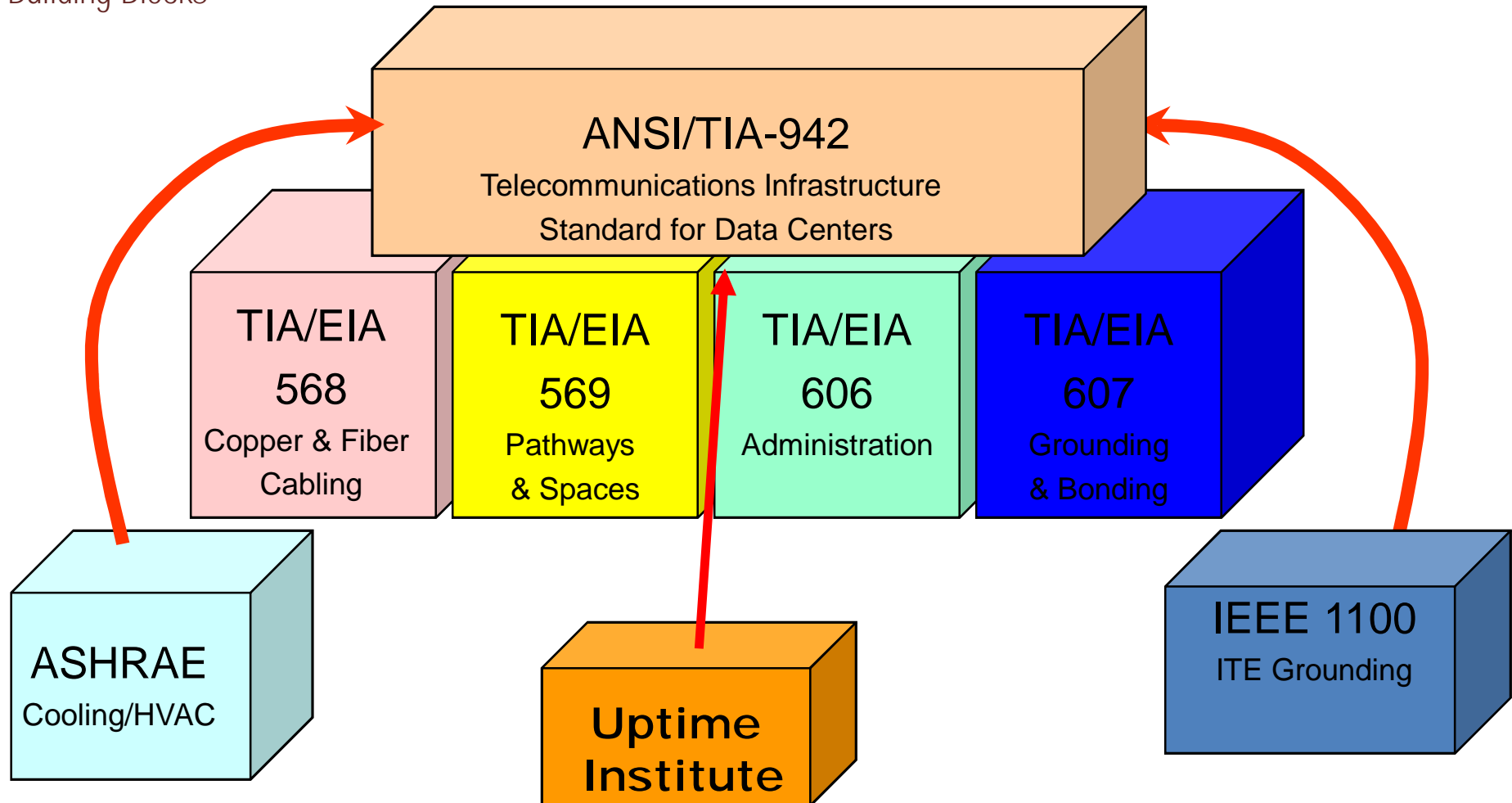

ZAIN +964 (0) 790-315-5118

ZAIN +964 (0) 781-201-8226

ASIACELL +964 (0) 770-434-0798

www.alamoodengineering.com

info@alamoodengineering.com



Qumit Al-Amood Engineering

Tier Level Requirements

	Tier I Basic	Tier II Redundant Components	Tier III Concurrently Maintainable	Tier IV Fault Tolerant
Site Availability	99,671%	99,749%	99,982%	99,995%
Downtime (Hours/Year)	28,8	22,0	1,6	0,4
Operations Center	Not Required	Not Required	Required	Required
Redundant Access Provider Services	Not Required	Not Required	Required	Required
Redundant Backbone Pathways	No	No	Yes	Yes
Redundant Horizontal Cabling	No	No	No	Optional
UPS Redundancy	N	N+1	N+1	2N
Gaseous Suppression System	No	No	Clean Agents FM200/Intergen	Clean Agents FM200/Intergen

ZAIN +964 (0) 790-315-5118

ZAIN +964 (0) 781-201-8226

ASIACELL +964 (0) 770-434-0798

www.alamoodengineering.com

info@alamoodengineering.com



Qumit Al-Amood Engineering

Hot Aisle / Cold Aisle

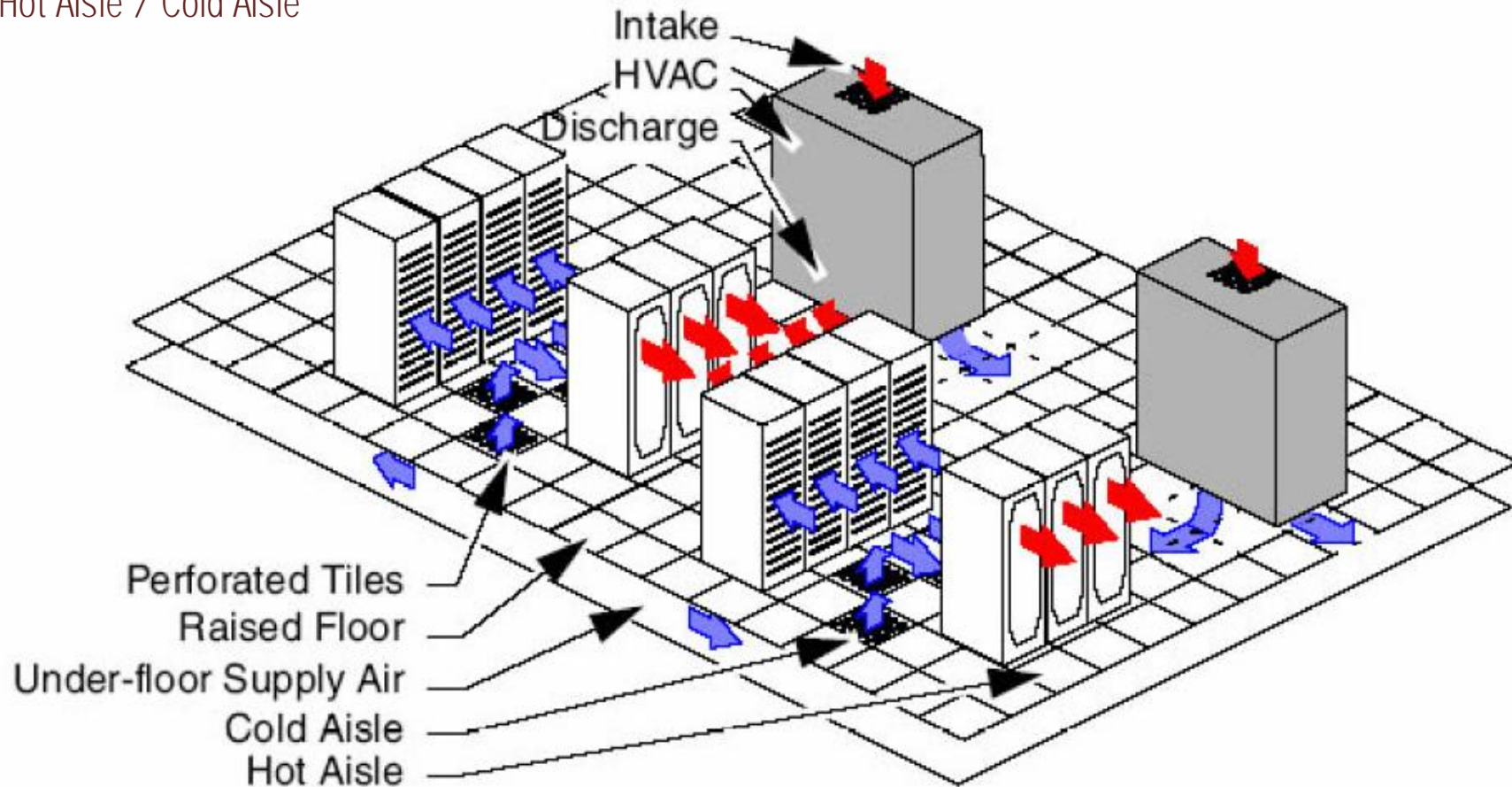

Based on ASHRAE "Thermal Guidelines for Data Processing Environments"

ZAIN +964 (0) 790-315-5118

ZAIN +964 (0) 781-201-8226

ASIACELL +964 (0) 770-434-0798

www.alamoodengineering.com

info@alamoodengineering.com



Qumit Al-Amood Engineering

Cable Placement

Put Data cables in HOT aisles, up high

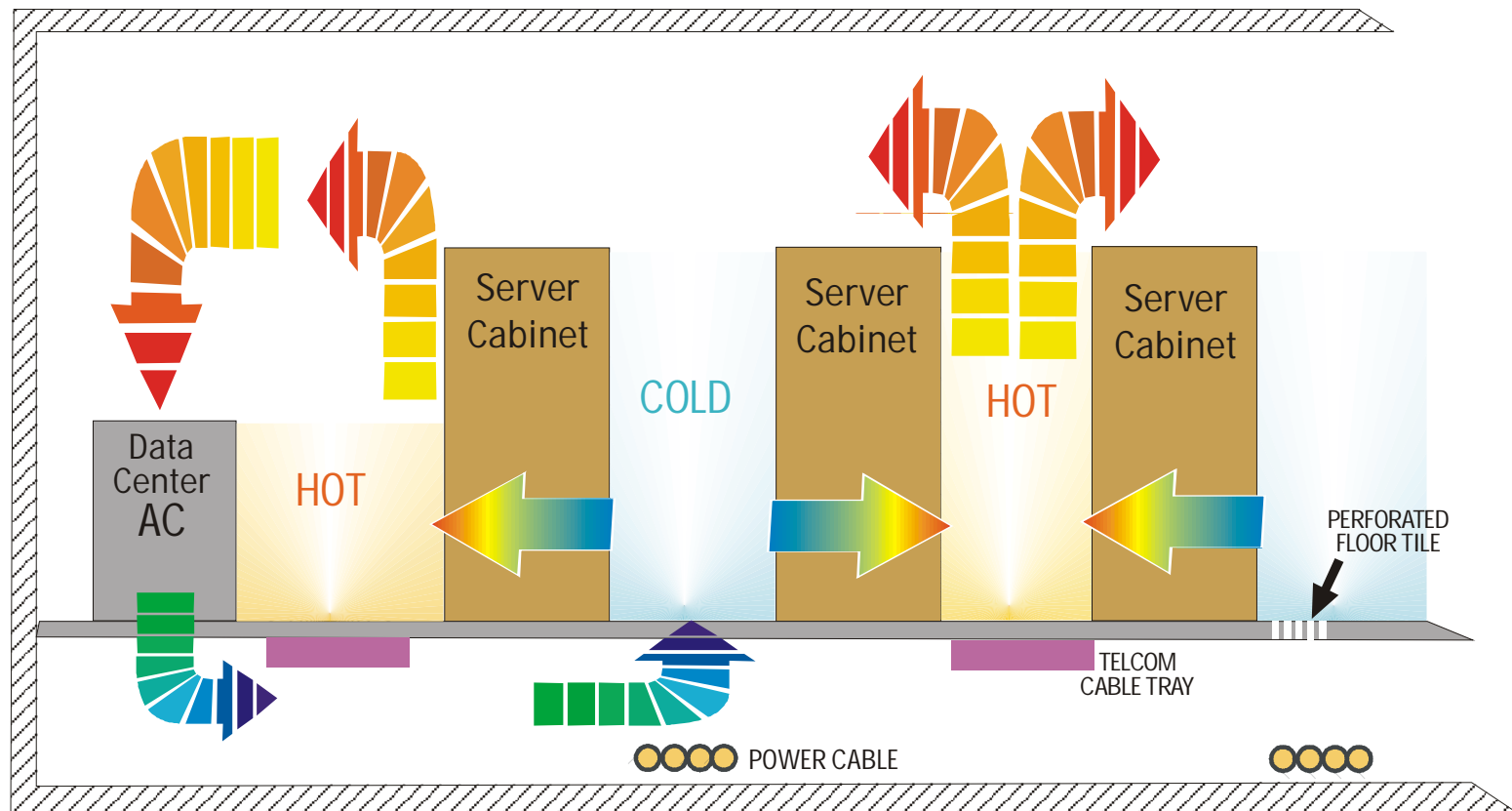

Put POWER cables in COLD aisles, down low

ZAIN +964 (0) 790-315-5118

www.alamoodengineering.com

ZAIN +964 (0) 781-201-8226

info@alamoodengineering.com

ASIACELL +964 (0) 770-434-0798



Qumit Al-Amood Engineering

TIA-942 Logical Layout

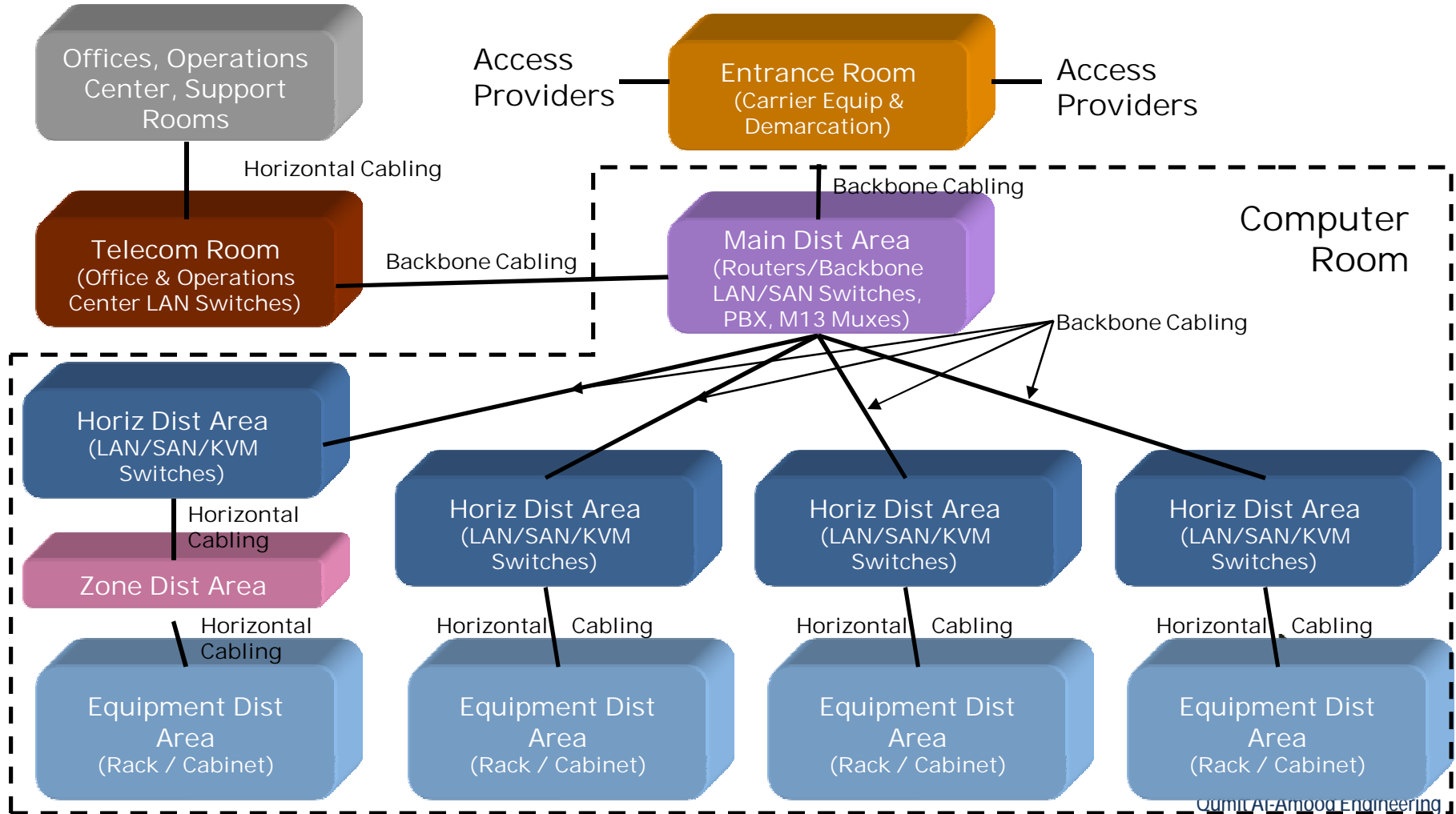

ZAIN +964 (0) 790-315-5118

www.alamoodengineering.com

ZAIN +964 (0) 781-201-8226

info@alamoodengineering.com

ASIACELL +964 (0) 770-434-0798

Qumit Al-Amood Engineering



Qumit Al-Amood Engineering

Example Data Center Layout

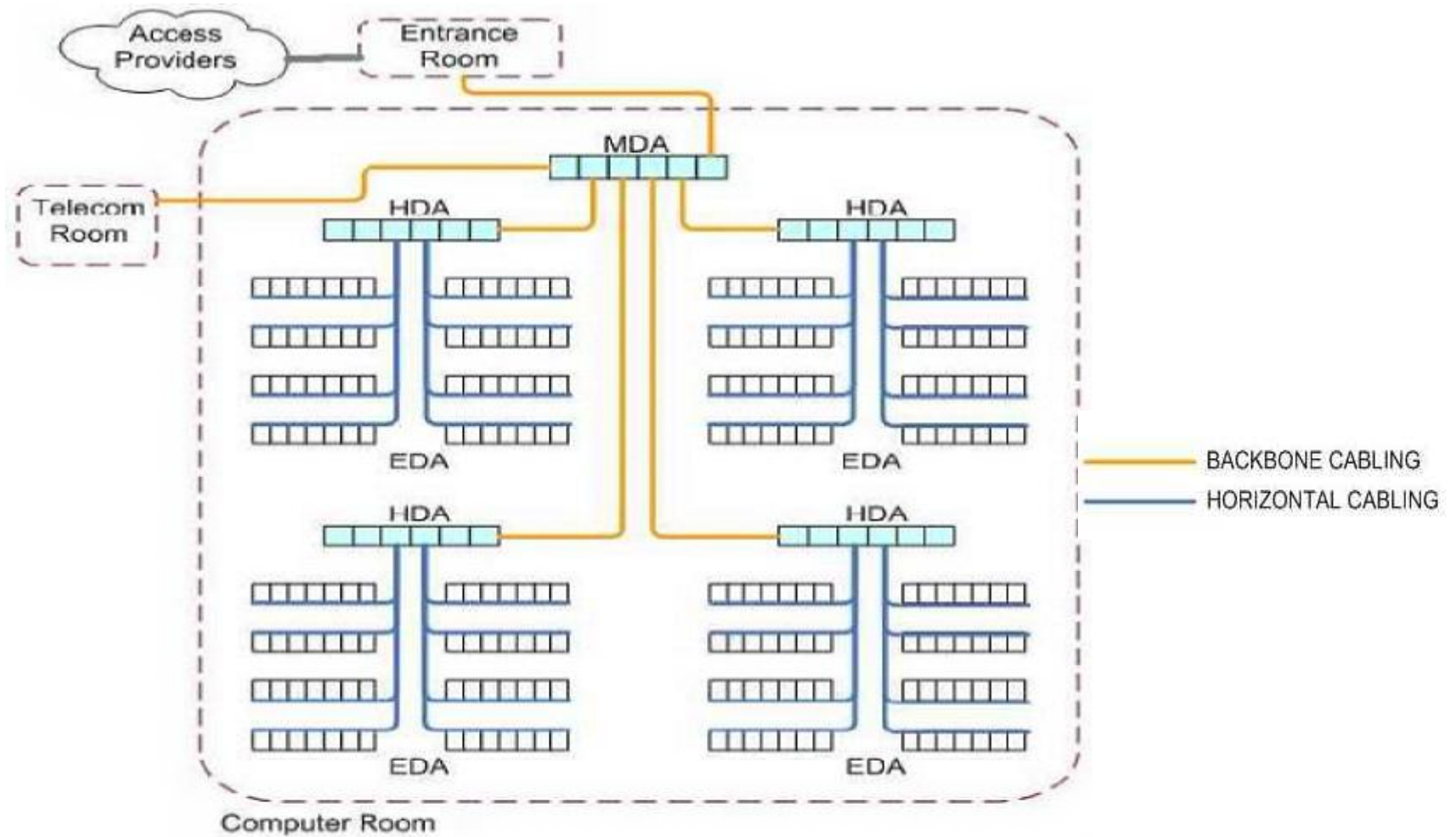

ZAIN +964 (0) 790-315-5118

ZAIN +964 (0) 781-201-8226

ASIACELL +964 (0) 770-434-0798

www.alamoodengineering.com

info@alamoodengineering.com



Qumit Al-Amood Engineering

Key Technology Initiatives

- 10 Gigabit Ethernet
 - 50mm multimode fiber, or UTP/STP configurations
- Grounding
 - Often overlooked BUT critical for highly reliable networks
- Managed Network Systems
 - Improves manageability and visibility of the entire network
- Cable Management
 - Changing to meet the dynamics of new equipment designs
- Pathways
 - Growing in importance due to real estate constraints and cooling effects
- Identification
 - Ensures accurate and reliable component traceability

ZAIN +964 (0) 790-315-5118

ZAIN +964 (0) 781-201-8226

ASIACELL +964 (0) 770-434-0798

www.alamoodengineering.com

info@alamoodengineering.com



Qumit Al-Amood Engineering

Tackling Data Center Issues

Meet Required SLA
Support Mission Critical
Applications

**Reliability /
Availability**

Reduce Operating Costs
Provide a "Complete"
View of the Network

Manageability

Safe from External and
Internal Threats

Scalability

Security

Facilitate Expansion
Support New Applications

ZAIN +964 (0) 790-315-5118

ZAIN +964 (0) 781-201-8226

ASIACELL +964 (0) 770-434-0798

www.alamoodengineering.com

info@alamoodengineering.com



Qumit Al-Amood Engineering

QAE's Value Proposition

- QAE can deliver and integrate end-to-end solution, or solutions to address specific business problems:
 - Constructing facilities:
 - Data network design
 - Network infrastructure & cabling
 - Operating & maintaining the workplace efficiently:
 - Branded subsystems, reliable solutions & equipment
 - Integration, implementation & setup
 - Support & maintenance
 - Managing the business:
 - Local / remote management
 - Application consolidation
 - Managed services

ZAIN +964 (0) 790-315-5118

ZAIN +964 (0) 781-201-8226

ASIACELL +964 (0) 770-434-0798

www.alamoodengineering.com

info@alamoodengineering.com



Qumit Al-Amood Engineering

Benefits

- All-in-one integrated umbrella BMS solution
- Visibility of operations
- High-tech advanced services
- Advanced safety & security
- Dramatically reduced OPEX
- Less downtime
- Occupant comfort – everything at hand and readily available
- Organizational flexibility
- Energy savings

ZAIN +964 (0) 790-315-5118

www.alamoodengineering.com

ZAIN +964 (0) 781-201-8226

info@alamoodengineering.com

ASIACELL +964 (0) 770-434-0798



Qumit Al-Amood Engineering

Why QAE

Vast experience in designing, implementing, supporting and operating integrated voice / data / video / mobility in large complex networks.

Multi-national footprint in the UAE , KSA, QATAR, UK, HOLLAND, SWITZERLAND, GREECE, CYPRUS.

Best-of-breed strategic alliances.

High profile engineers & technicians , BICSI members , trained to highest vendors level in order to provide you best Service.

ZAIN +964 (0) 790-315-5118

www.alamoodengineering.com

ZAIN +964 (0) 781-201-8226

info@alamoodengineering.com

ASIACELL +964 (0) 770-434-0798



QUMIT AL-AMOOD ENGINEERING

ZAIN +964 (0) 790-315-5118

ZAIN +964 (0) 781-201-8226

ASIACELL +964 (0) 770-434-0798

www.alamoodengineering.com

info@alamoodengineering.com